

PAC-4070

Programmable Automation Controller

User Guide

Version 1.1



Table of Contents

| | | |
|-----------|---|----------|
| 1. | Introduction | 1 |
| 1.1 | Features | 1 |
| 1.2 | Packing List..... | 1 |
| 1.3 | Optional Accessory | 1 |
| 2. | Layout | 2 |
| 3. | Pin Assignment and Definition..... | 3 |
| 3.1 | Reset Button | 3 |
| 3.2 | Power LED | 3 |
| 3.3 | Ready LED..... | 3 |
| 3.4 | Link / Act LED | 3 |
| 3.5 | Serial Port LED | 3 |
| 3.6 | Ethernet Port | 3 |
| 3.7 | Serial Port | 3 |
| 3.8 | Serial Console Port | 4 |
| 3.9 | Power Input Connector | 5 |
| 3.10 | Analog Input Connector (AI+, AI-)..... | 5 |
| 3.11 | Digital Output Connector (DO1 ~ DO4, DO GND, DO VCC)..... | 6 |
| 3.12 | Digital Input Connector | 6 |
| 3.13 | Factory Default Settings..... | 7 |
| 3.14 | Power on and System Boot up | 7 |
| 3.15 | Inittab and Run Levels | 8 |
| 3.16 | Default Started Service | 8 |
| 3.17 | Network Settings | 8 |
| 3.18 | Insert Kernel Module | 8 |
| 3.19 | File System | 9 |
| 3.20 | Devices List..... | 10 |
| 3.21 | Utility Software | 10 |
| 3.22 | Mounting External Storage Memory | 10 |
| 3.23 | Welcome Message | 11 |
| 3.24 | Web Page Directory | 11 |

| | | |
|-----------|--|-----------|
| 3.25 | Adjust the System Time | 11 |
| 3.26 | SSH Console..... | 12 |
| 3.27 | Putty Console Software | 12 |
| 3.28 | ipkg Package Software Management | 12 |
| 3.29 | Install GNU Toolchain | 13 |
| 3.30 | Getting Started with the Hello Program | 13 |
| 3.31 | Auto Start Program on Boot..... | 14 |
| 4. | Artila Utility Software | 15 |
| 4.1 | update | 15 |
| 4.2 | setuart | 15 |
| 4.3 | setconsole | 15 |
| 4.4 | version..... | 16 |
| 4.5 | gpioctl..... | 16 |
| 4.6 | setadc..... | 16 |
| 4.7 | How to Read Analog Input Data | 16 |
| 5. | Loader Menu | 17 |
| 6. | Frequently Asked Question..... | 18 |
| 6.1 | Forgot Password | 18 |
| 6.2 | Forgot the IP Address | 18 |
| 6.3 | System Fail to Boot..... | 18 |
| 7. | System Recovery | 19 |
| 7.1 | Update Image..... | 19 |
| 7.2 | Make Filesystem | 19 |
| 7.3 | Recovery Env..... | 19 |
| 7.4 | Show Info | 19 |
| 7.5 | Reboot..... | 19 |
| 7.6 | Update Image Starts | 20 |
| 7.7 | Update Image Completes | 20 |
| 7.8 | Make Files System Starts | 20 |
| 8. | Appendix..... | 21 |
| 8.1 | Utility Collection..... | 21 |
| 8.2 | ipkg Software Package Management | 21 |

1. Introduction

PAC-4070 is an ARM9-based Linux ready industrial controller.

1.1 Features

- ARM926EJ-S ARM Thumb Processor 400MHz w/MMU
- 32-KByte Data Cache and 32-KByte Instruction Cache
- 64MB SDRAM, 256MB NAND Flash on board
- Two 10/100Mbps Ethernet
- Two USB 2.0 full speed (12Mbps) Host Ports, one USB device port
- Multimedia Card Interface for microSD memory card
- Four serial ports: RS-232 x 2 and RS-232 x 2 or Isolated RS-485 x 2
- Four channel isolated analog input with accurate 16-bit A/D
- Four channels 2500Vrms isolated photo coupler digital input (Bipolar)
- Eight channels 2500Vrms isolated Darlington digital output
- 9 to 40VDC power input
- Pre-installed Standard Linux 2.6 OS
- GNU tool chain available on Artilla FTP
- DIN RAIL mounting

1.2 Packing List

- PAC-4070 Programmable Automation Controller
- DIN Rail bracket

1.3 Optional Accessory

- CB-RJ45F9-150 (91-R45F9-150): Serial Cable (RJ45 to DB9 Female, 150cm)
- CB-PHDF9-050 (91-PHDF9-050): Console Cable (Wafer Box to DB9 Female, 50cm)
- PWR-12V-1A (31-62100-000): 110~240VAC to 12VDC 1A Power Adaptor

2. Layout

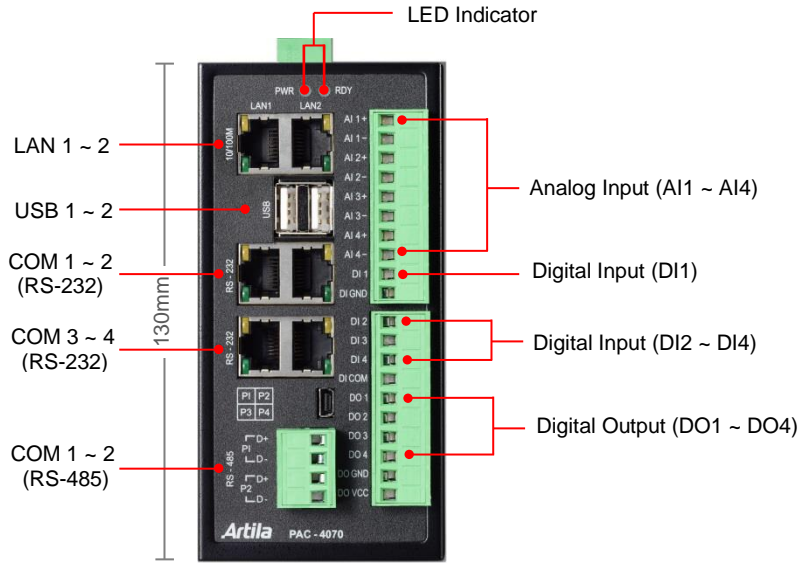

Top of PAC-4070

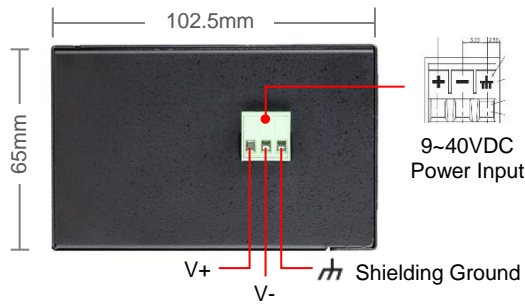

Back of PAC-4070



Bottom of PAC-4070

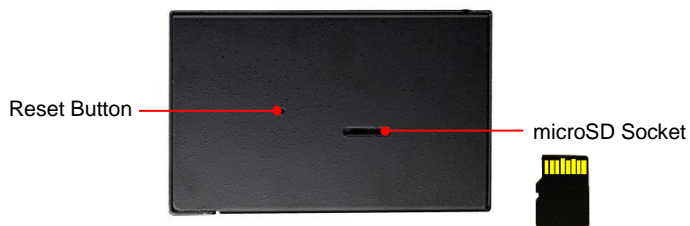

3. Pin Assignment and Definition

3.1 Reset Button

Press the “Reset” button to activate the hardware reset. You should only use this function if the software reboot does not function properly.

3.2 Power LED

The Power LED will show solid green if power is properly applied.

3.3 Ready LED

The Ready LED will show solid green if PAC-4070 complete system boot up. If Ready LED is off during system boot up, please check if power input is correct. Turn off the power and restart PAC-4070 again. If Ready LED is still off, please contact the manufacture for technical support.

3.4 Link / Act LED

When Ethernet port are connected to the network, Link LED will show solid green. If there is traffic is the Ethernet line, the yellow Act LED will flash.

3.5 Serial Port LED

When RXD line is high then Yellow light is ON and when TXD line is high, Green light is ON.

3.6 Ethernet Port

| Pin | Signal |
|-----|--------|
| 1 | ETx+ |
| 2 | ETx- |
| 3 | ERx+ |
| 6 | ERx- |

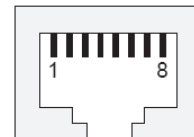

3.7 Serial Port

- **Port 1~2:** Software selectable RS-232 or isolated RS-485. If RS-485 is chosen, please use terminal block connector for RS-485.
- **Port 3~4:** RS-232 port with hardware flow control.

Note

Only Port 2 support RS-232 full modem control DSR, DCD and DTR.

| Pin | RS-232 |
|-----|--------|
| 1 | DSR |
| 2 | RTS |
| 3 | GND |
| 4 | TXD |
| 5 | RXD |
| 6 | DCD |
| 7 | CTS |
| 8 | DTR |

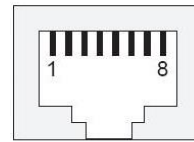

3.8 Serial Console Port

Serial console port is located inside the box at JP4 of M-502. You need a special console cable (91-PHDF9-050) to access it.

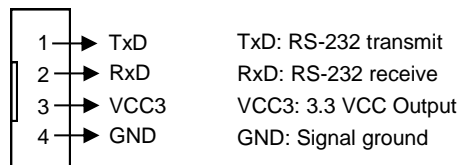

Use any terminal software such as hyper terminal and configure the setting as follow:

Baud rate: 115200

Data bits: 8

Parity: N

Stop bit: 1

Terminal type: VT100

Note

We provide a utility software, **setconsole** to redirect the console port to any one of the serial port. Therefore user do not need to open the case to access the physical console port. Please refer to **setconsole** command in the Artila utility section.

```

Finished to configure packages.
INIT: Entering runlevel: 5
Starting system message bus: dbus.
Starting ssh server: done.
Starting amgrd: done
Starting syslogd/klogd: done
Starting Telnet Server: done
Starting FTP Server: vsftpd... done.
Starting Lighttpd Web Server: lighttpd.
Starting Ready LED: done

PAC-4000 login: guest
Password:

  A  A  A  A  A  A  A  A  A  A
 A  A  A  A  A  A  A  A  A  A
A  A  A  A  A  A  A  A  A  A

http://www.artila.com
guest@PAC-4000:~$
    
```

3.9 Power Input Connector

PAC-4070 uses +9VDC to 40VDC power and input from three ports plug-in screw terminal connector. Auto-polarity and surge protection are included in power input circuitry of PAC-4070 to provide power protection. Shielding ground provides better EMI protection. Please wire the shielding ground to an appropriate grounded metal surface.

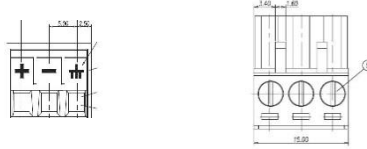

3.10 Analog Input Connector (AI+, AI-)

Each of the 4 channels isolated analog input can be configured as various input range and the common features are show as follow:

Effective Resolution: 16-bit

Channels: four differential input channels

Input Type: mV, V, mA

Input Range:

Uni-polar: 0~150mV, 0~500mV, 0~1V, 0~5V, 0~10V

Bi-polar: +/- 150mV, +/- 500mV, +/- 1V, +/- 5V, +/- 10V

Current: 0~20mA

Sampling Rate: 10~100 samples/sec

Input Impedance: 20M Ω

Accuracy: +/- 0.1%

CMR: 50/60Hz 100dB

Isolation: 1500Vrms (Three-way)

The analog input channels provide 1500Vrms isolation. Therefore, to measure a floating signal such as a battery and single-ended source, simply connect the positive signal to AI+ and negative (ground) signal to AI- to perform a differential measurement.

To measure current input, please set the jumper (JP1~JP4) to position 2-3 to shunt the 120ohm resistor on board for current measurement.

Input Type Selection Jumper JP1~JP4



Voltage Input: 1-2 (default)
Current Input: 2-3

Analog Input Block Diagram

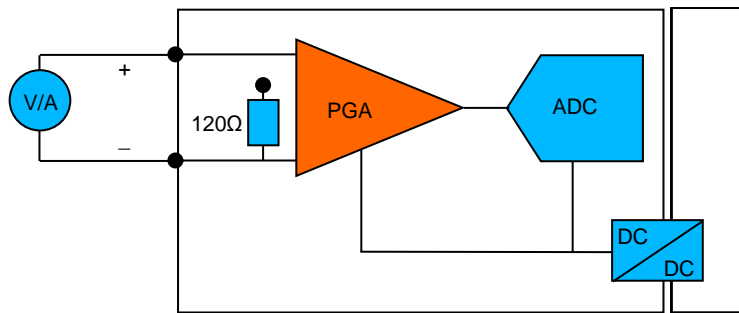

3.11 Digital Output Connector (DO1 ~ DO4, DO GND, DO VCC)

The digital output are equipped with 4 darlington pair transistors (Allegro UDN2981A) to switch the external relay or solenoid. The internal transient-suppression diodes permit the drive to be used with inductive load. The source voltage of the drive is from 5Vdc to 50Vdc and the maximum driving current is 500mA. 2500Vrms isolation is provided in all 4 DO ports.

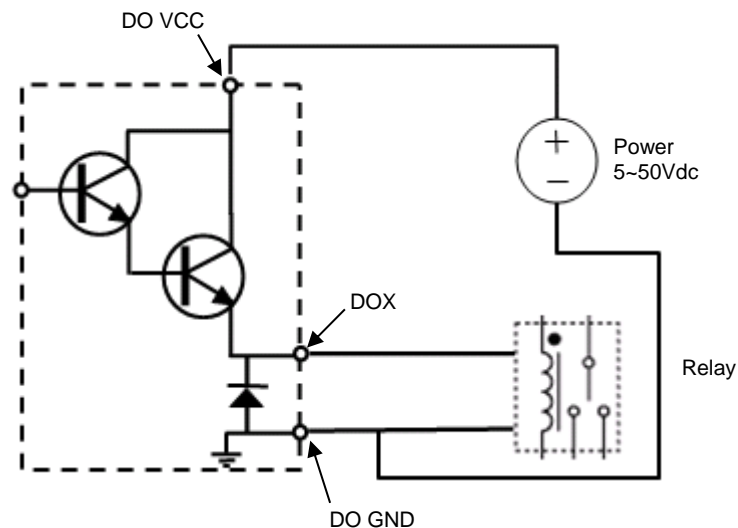

DOX: DO output channels

DO GND: Ground of DO (Darlington)

DO VCC: External voltage source of DO

3.12 Digital Input Connector

The 4 channel isolated input are equipped with 2500Vrms photo coupler. DI1 uses DI GND and DI2 to DI4 share command ground, DI COM. The specification of the isolated input channels are:

Logical High: 5~24Vdc

Logical Low: 0~1.5Vdc

Input resistance: 1.2KOhms @0.5W

Response time: 20μs

Isolation: 2500Vrms

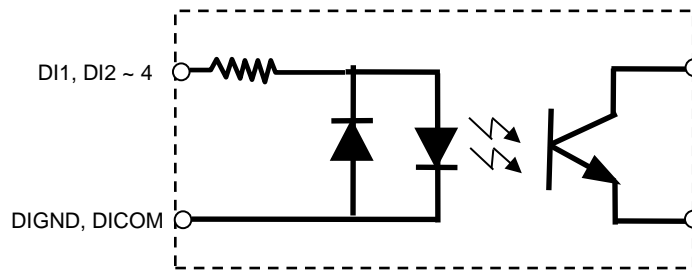

3.13 Factory Default Settings

LAN 1 IP Address: 192.168.2.127

LAN 2 IP Address: 192.168.3.127

Login: root or guest (telnet guest only)

Password: root or guest (telnet guest only)

Serial Console Port:

Baud rate: 115200

Data format: 8 Bits, No Parity, 1 Stop bit (N,8,1)

Flow Control: None

Terminal type: VT100

3.14 Power on and System Boot up

Once PAC-4070 is correctly power on, it will start boot Linux kernel and mount file system. You can use Ethernet and telnet and login PAC-4070. Once kernel loaded, it will find */sbin/init* and execute it. The initialization configuration is at */etc/inittab*. Once boot up, you can use telnet to login PAC-4070.

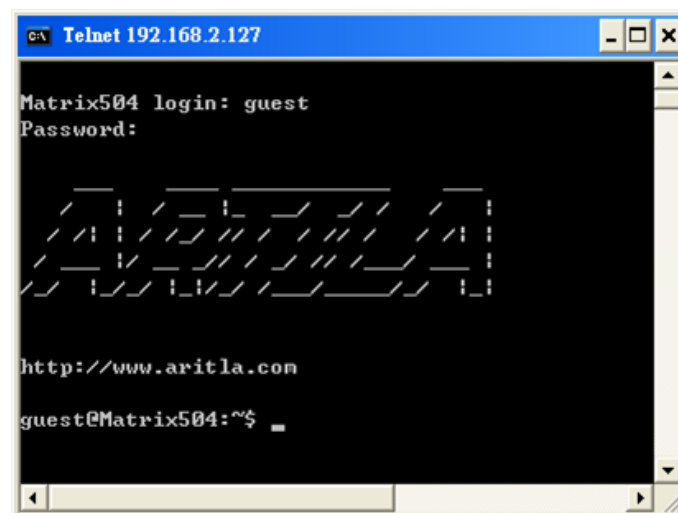

3.15 Inittab and Run Levels

Inittab contains information of system initialization. The system initialization script `/etc/rcS.d` runs first then the run level 5 `/etc/rc5.d`. PAC-4010 uses run level for system setup and the default run level is number 5. Please refer to introduction to linux (<http://tille.garrels.be/training/tldp/>) for information about run level. Following is the run levels setting:

Run level 0: halt

Run level 1 is single user (login and service are disabled)

Run level 2~5 are multiple users

Run level 6 is reboot

Please refer to loader menu section for selection of run level.

3.16 Default Started Service

1. amgrd (Artilla broadcast search daemon)
2. ssh (secured shell) with sftp
3. syslog/klogd (system and kernel log)
4. telnet server (disable root with `/etc/securetty`)
5. ftp server (vsftp)
6. web server (apache2)
7. Ready LED (debug LED for internal use)

3.17 Network Settings

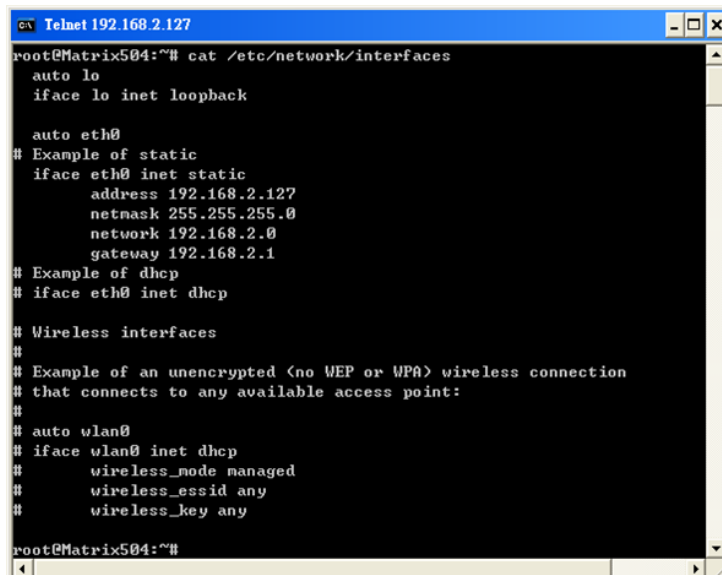

```
root@Matrix504:~# cat /etc/network/interfaces
auto lo
iface lo inet loopback

auto eth0
# Example of static
iface eth0 inet static
    address 192.168.2.127
    netmask 255.255.255.0
    network 192.168.2.0
    gateway 192.168.2.1
# Example of dhcp
# iface eth0 inet dhcp

# Wireless interfaces
#
# Example of an unencrypted (no WEP or WPA) wireless connection
# that connects to any available access point:
#
# auto wlan0
# iface wlan0 inet dhcp
#     wireless_mode managed
#     wireless_essid any
#     wireless_key any
root@Matrix504:~#
```

3.18 Insert Kernel Module

To insert kernel module while system boot up, please use `vi` to edit `/etc/modules` to add module to load e.g.

rt73usb

To load the USB WLAN adaptor.

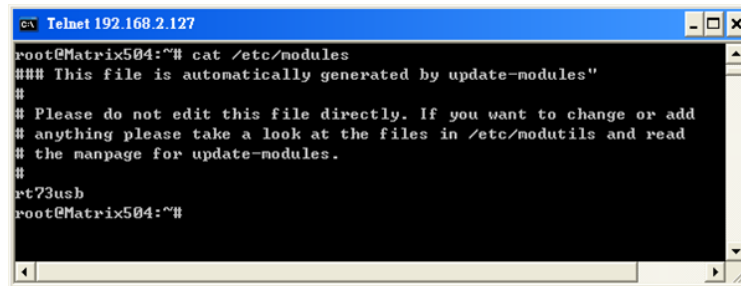

```

Telnet 192.168.2.127
root@Matrix504:~# cat /etc/modules
### This file is automatically generated by update-modules"
#
# Please do not edit this file directly. If you want to change or add
# anything please take a look at the files in /etc/modutils and read
# the manpage for update-modules.
#
rt73usb
root@Matrix504:~#

```

Use **vi** editing tool to edit the **/etc/network/interfaces** for network setting. The default setting is static IP 192.168.2.127. PAC-4070 also supports Wireless LAN. Use

wireless_essid XXX

wireless_key YYY

To add SSID and WEP key if necessary. XXX is SSID and YYY is WEP Key.

PAC-4070 supports USB WLAN adaptor (Ralink RT2571). You can enable the driver module (rt73usb) by adding **rt73usb** in

/etc/modules

3.19 File System

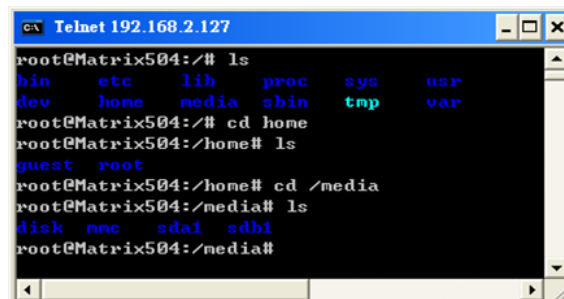

```

Telnet 192.168.2.127
root@Matrix504:/# ls
bin  etc  lib  proc  sys  usr
dev  home media sbin tmp  var
root@Matrix504:/# cd home
root@Matrix504:/home# ls
guest root
root@Matrix504:/home# cd /media
root@Matrix504:/media# ls
disk mmc sdai sdbi
root@Matrix504:/media#

```

The 256MB NAND Flash memory of PAC-4070 contains Boot loader (uBoot), Linux Kernel, Root File System and user disk (/home). The file system and disk space are shown as follow.

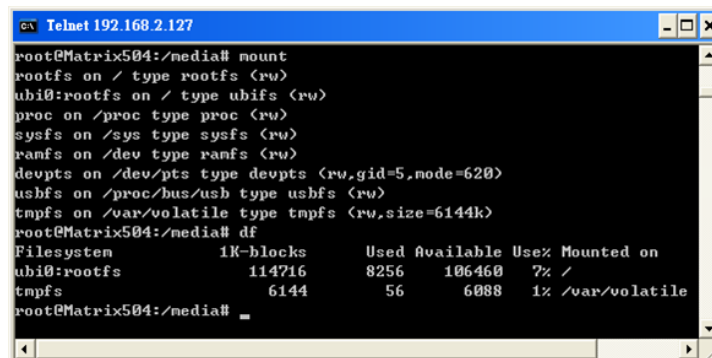

```

Telnet 192.168.2.127
root@Matrix504:/media# mount
rootfs on / type rootfs (rw)
ubi0:rootfs on / type ubifs (rw)
proc on /proc type proc (rw)
sysfs on /sys type sysfs (rw)
ramfs on /dev type ramfs (rw)
devpts on /dev/pts type devpts (rw,gid=5,mode=620)
usbfs on /proc/bus/usb type usbfs (rw)
tmpfs on /var/volatile type tmpfs (rw,size=6144k)
root@Matrix504:/media# df
Filesystem            1K-blocks      Used Available Use% Mounted on
ubi0:rootfs           114716         8256   106460    7% /
tmpfs                 6144            56     6088    1% /var/volatile
root@Matrix504:/media#

```

3.20 Devices List

The supported devices are shown at /dev directory. Following list are most popular ones:

1. ttyS0: serial console port
2. ttyS1 to ttyS4: serial port 1 to port 4
3. sda to sdb: USB flash disk
4. ttyUSB0 to ttyUSB1: USB RS-232 adaptor (fdt_i_sio.ko)
5. rtc: Real Time Clock
6. gpio: Digital I/O
7. adc: A/D channel
8. ttyACM0 and ttyACM1: USB Modem (CDC compliant)
9. mmc: SD driver

3.21 Utility Software

PAC-4070 includes busybox utility collection and Artila utility software and there are placed at:

/sbin

/bin

/usr/bin

/use/sbin

Please refer to Appendix for the utility collection list.

```

Telnet 192.168.2.127
root@Matrix504:/sbin# ls
arp          init         lsush       setconsole
depmod       init.sysvinit makedevs   shutdown
depmod.26   insmod      mkdosfs    shutdown.sysvinit
fdisk        iucfg       mkfs.minix start-stop-daemon
fsck         iugetid     mkfs.vfat  sulogin
fsck.minix  iulst       nkswap     swapoff
getty        iopriv      modprobe   swapon
halt         iuspy       pivot_root switch_root
halt.sysvinit killall5     poweroff   sysctl
hotplug     klogd       reboot     sysctl.procps
hwclock     ldconfig    reboot.sysvinit syslogd
ifconfig    logread     rmmod      telinit
ifdown      losetup     route      udhcpc
ifup        lsmod       runlevel

root@Matrix504:/sbin# cd /bin
root@Matrix504:/bin# ls
addgroup    dmesg       nktmp      sh
adduser     echo        more       sleep
bash        egrep       mount      stty
bashbug     false      mount.util-linux su
busybox     fgrep       mountpoint sync
cat          grep        mv          tar
chatr       gunzip      netstat    touch
chgrp       gzip        pidof      true
chmod       hostname    pidof.sysvinit umount
chown       ip          ping        umount.util-linux
cp          kill        ps          uname
cpio        kill.procps ps.procps  usleep
date        ln          pwd         vi
dd          login       ra          zcat
delgroup    ls          rmdir
deluser     mkdir      run-parts
df          mknod      sed

```

3.22 Mounting External Storage Memory

To find out the device name of the external memory device which plug into PAC-4070, you can use the command:

dmesg | grep sd

dmesg | grep mmc

To find out the device type (sda, sdb or mmc).

And use

```
mount /dev/sda1
```

```
mount /dev/mmc
```

to mount the USB disk or SD card and folder is local at

```
media/sda1 or /mnt/sda1
```

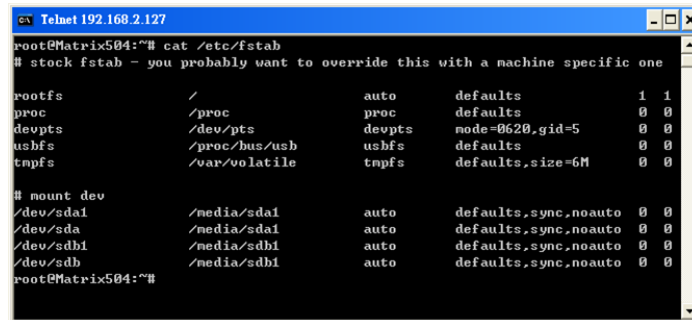

```

Telnet 192.168.2.127
root@Matrix504:~# cat /etc/fstab
# stock fstab - you probably want to override this with a machine specific one

rootfs / auto defaults 1 1
proc /proc proc defaults 0 0
devpts /dev/pts devpts mode=0620,gid=5 0 0
usbfs /proc/bus/usb usbfs defaults 0 0
tmpfs /var/volatile tmpfs defaults,size=6M 0 0

# mount dev
/dev/sda1 /media/sda1 auto defaults,sync,noauto 0 0
/dev/sda /media/sda1 auto defaults,sync,noauto 0 0
/dev/sdb1 /media/sdb1 auto defaults,sync,noauto 0 0
/dev/sdb /media/sdb1 auto defaults,sync,noauto 0 0
root@Matrix504:~#

```

3.23 Welcome Message

To modify the welcome message, user can use text edit to modify the */etc/motd*.

3.24 Web Page Directory

The web pages are placed at */usr/www* and the */etc/lighttpd.conf* contains the lighttpd web server settings. The home page name should be *index.html*.

3.25 Adjust the System Time

To adjust the RTC time, you can follow the command:

```
date MMDDhhmmYYYY
```

where

MM=Month (01~12)

DD=Date (01~31)

hh=Hour

mm=minutes

YYYY=Year

```
hwclock -w
```

To write the date information to RTC.

User can also use NTP client utility on Artila FTP to adjust the RTC time.

```
ntpclient [time server ip]
```

3.26 SSH Console

PAC-4070 supports SSH. If you use Linux computer, you can use SSH command to login PAC-4070.

The configuration of SSH and key are located at */etc/ssh*.

The key generation program is available at */usr/bin*.

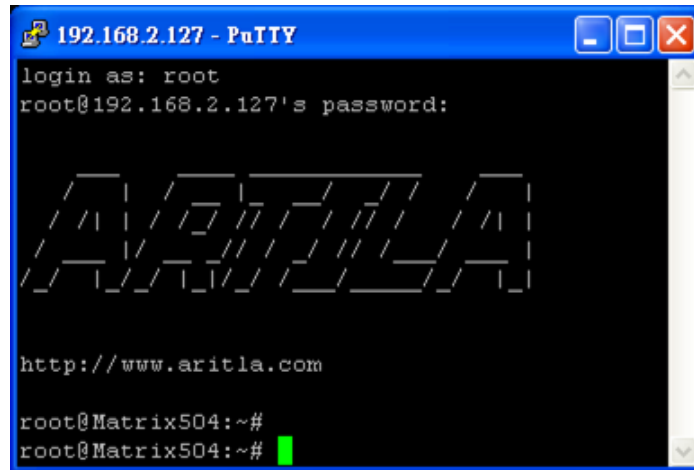

3.27 Putty Console Software

For Windows user, you can download the putty software at

<http://www.chiark.greenend.org.uk/~sgtatham/putty/download.html> to use SSH to login PAC-4070.

3.28 ipkg Package Software Management

ipkg is a light software package utility. It can be used to install, upgrade and remove the software package for PAC-4070. Currently user can use ipkg to install the software package from Artila FTP.

You can find the configuration at *ipkg.conf*.

When PAC-4070 is connected to network and issue command:

ipkg update

To update the package list and use

ipkg install

To install software package and

ipkg remove

To remove software

ipkg list

To list available software

ipkg list_installed

To list software installed

Please refer to Appendix for more about ***ipkg***.

3.29 Install GNU Toolchain

Find a PC with Linux OS installed as followed:

Fedore 7, ubuntu 7.04, OpenSUSE 10.2, Mandriva 2008, Debian 5.0, Centos (RedHat) 5 and above.

Login as a root user then copy the arm-linux-4.3.2.tar.gz to root directory of PC. Under root directory, type following command to install the PAC-4070 Toolchain:

```
#tar -xvfj arm-linux-4.3.3.tar.bz2
```

The toolchain file name are:

```
arm-linux-gnueabi-gcc
```

```
arm-linux-gnueabi-g++
```

```
arm-linux-gnueabi-strip
```

Version: gcc 4.3.3, glibc 2.9, binutils 2.18

For Windows user, please download the toolchain from CodeSourcery at

<http://www.codesourcery.com/sgpp/lite/arm/portal/package4547/public/arm-none-linux-gnueabi/arm-2009q1-203-arm-none-linux-gnueabi.exe>

The toolchain file name are:

```
arm-none-linux-gnueabi-gcc
```

```
arm-none-linux-gnueabi-g++
```

```
arm-none-linux-gnueabi-strip
```

Version: gcc 4.3.3, glibc 2.8, binutils 2.19

3.30 Getting Started with the Hello Program

There are many example programs on Artilla FTP. To compile the sample you can use the Make file and type:

```
make
```

To compile and link the library. Once done, use ftp command

```
ftp 192.168.2.127
```

Then login with password. Use bin command to set transfer mode to binary

```
ftp>bin
```

To transfer the execution file to PAC-4010 user disk (/home/guest) and use

```
chmod +x file.o
```

To change it to execution mode and

```
./file.o
```

to run the program.

3.31 Auto Start Program on Boot

To start a program on boot, you can use */etc/rc.local*.

For example to use *vi* to edit *rc.local*

```
hello &
```

```
exit 0
```

Hello will be executed after system boot up. *rc.local* has the similar function as */etc/rc* in PAC-4070.

4. Artila Utility Software

The introduction of Artila utility software as follow:

4.1 update

Update loader, environment file and kernel image. Type **update--help** to find the command usage.

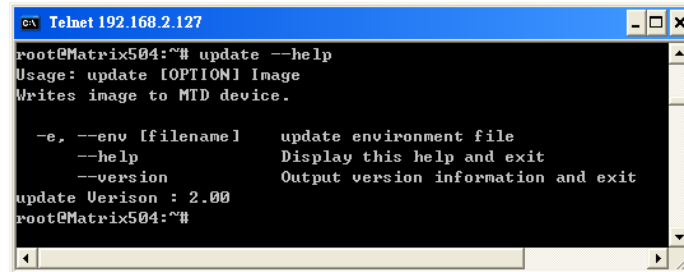

```

root@Matrix504:~# update --help
Usage: update [OPTION] Image
Writes image to MTD device.

  -e, --env [filename]  update environment file
  --help                Display this help and exit
  --version             Output version information and exit
update Verison : 2.00
root@Matrix504:~#

```

Update can only operate under supervisor mode (password: root). Please use command **su** and login as root.

4.2 setuart

Configure serial port setting. An example show as followed to configure port 1 as RS-485 interface with baud rate 921600.

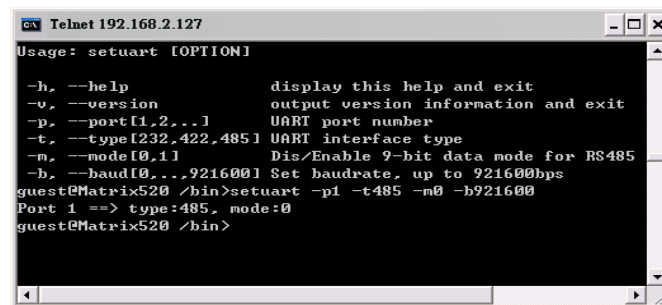

```

Usage: setuart [OPTION]

-h, --help            display this help and exit
-v, --version         output version information and exit
-p, --port[1,2,...]  UART port number
-t, --type[232,422,485] UART interface type
-m, --mode[0,1]      Dis/Enable 9-bit data mode for RS485
-b, --baud[0,...921600] Set baudrate, up to 921600bps
guest@Matrix520 /bin>setuart -p1 -t485 -m0 -b921600
Port 1 ==> type:485, mode:0
guest@Matrix520 /bin>

```

4.3 setconsole

PAC-4070 is designed to use M-502 SoM as its CPU module. The console port is located at JP4 of M-502 module. User can use **setconsole** command to redirect the serial console port to any one of the four serial port of PAC-4070. Therefore user can avoid opening the metal case to access the serial console.

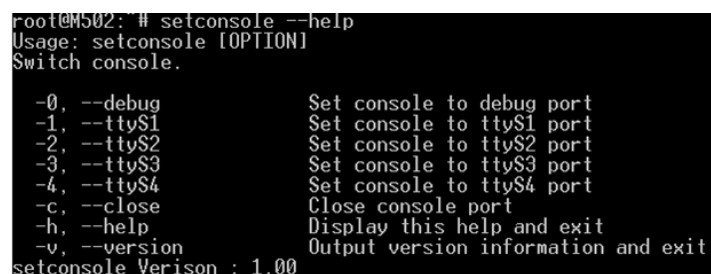

```

root@M502:~# setconsole --help
Usage: setconsole [OPTION]
Switch console.

-0, --debug          Set console to debug port
-1, --ttyS1          Set console to ttyS1 port
-2, --ttyS2          Set console to ttyS2 port
-3, --ttyS3          Set console to ttyS3 port
-4, --ttyS4          Set console to ttyS4 port
-c, --close          Close console port
-h, --help           Display this help and exit
-v, --version        Output version information and exit
setconsole Verison : 1.00

```

4.4 version

Find out the version of OS.

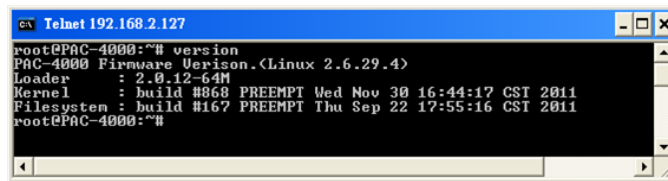

```

Telnet 192.168.2.127
root@PAC-4000:~# version
PAC-4000 Firmware Verison.(Linux 2.6.29.4)
Loader      : 2.0.12-64M
Kernel     : build #868 PREEMPT Wed Nov 30 16:44:17 CST 2011
Filesystem : build #167 PREEMPT Thu Sep 22 17:55:16 CST 2011
root@PAC-4000:~#

```

4.5 gpioctrl

The gpio can be configured by *gpioctrl* and the usage is as shown followed.

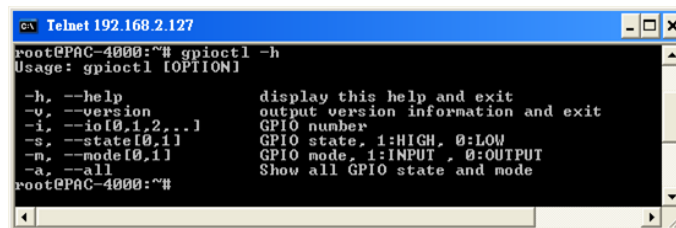

```

Telnet 192.168.2.127
root@PAC-4000:~# gpioctrl -h
Usage: gpioctrl [OPTION]

-h, --help            display this help and exit
-v, --version         output version information and exit
-i, --io[0,1,2,...]  GPIO number
-s, --state[0,1]     GPIO state, 1:HIGH, 0:LOW
-m, --mode[0,1]     GPIO mode, 1:INPUT, 0:OUTPUT
-a, --all            Show all GPIO state and mode
root@PAC-4000:~#

```

4.6 setadc

setadc is used to configure the analog input channels.

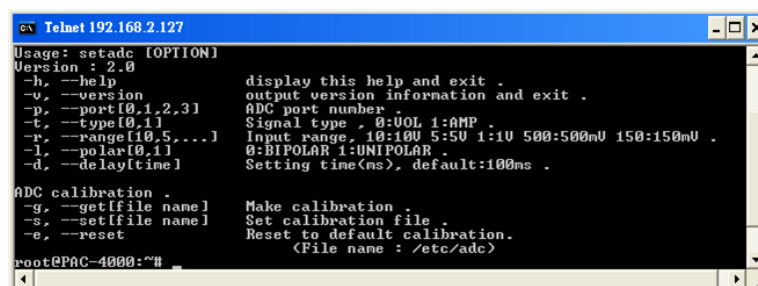

```

Telnet 192.168.2.127
Usage: setadc [OPTION]
Version : 2.0
-h, --help            display this help and exit .
-v, --version         output version information and exit .
-p, --port[0,1,2,3]  ADC port number .
-t, --type[0,1]     Signal type , 0:UOL 1:AMP .
-r, --range[10,5,...] Input range, 10:10U 5:5U 1:1U 500:500mV 150:150mV .
-l, --polar[0,1]    0:BIPOLAR 1:UNIPOLAR .
-d, --delay[time]   Setting time(ms), default:100ms .

ADC calibration .
-g, --get[file name] Make calibration .
-s, --set[file name] Set calibration file .
-e, --reset         Reset to default calibration.
                   (File name : /etc/adc)
root@PAC-4000:~#

```

4.7 How to Read Analog Input Data

To read the analog data of the input channel, please follow the steps below:

- Set the configuration of the analog channels [adc0~adc3]
- Repeatedly read data from the device [adc0~adc3]

Note

Please set the delay time to be 100ms or longer if you want to perform multiple channels scan. The ADC device driver will delay 100ms for Multiplexer and Programmable Gain Amplifier to be stable before taking the data from ADC.

5. Loader Menu

Loader menu helps user to select the run level of system boot up. User need to use serial console to enter loader menu. Please configure the serial port of terminal as follow:

Baud Rate: 115200
 Data bits: 8
 Parity: N
 Stop bit: 1
 Flow Control: None
 Terminal type: VT100

Once power up PAC-4070, please repeatedly keying “@” and you will see the loader menu appear as follow:

```
Starting M502.....
*****
          Artila Loader Version 2.0.9
          DRAM:64M NAND:128M
*****
G: Loader TFTP      L: Loader Serial
K: Kernel TFTP     S: Kernel Serial
F: Filesys TFTP    T: Filesys Serial
E: Env. Upgrade    M: Ethernet Setting
A: Dataflash Booting U: Runlevel
C: Switch Console  R: Reset
*****
```

If you miss the timing, please power on again the PAC-4070 and do it again. Select U will prompt the run level selection message. Run level 0 is halt, run level 1 is single user (disable login and service). Run level 2~5 are multiple users and run level 6 is reboot. To view the run level configuration, please check:

/etc/inittab

6. Frequently Asked Question

6.1 Forgot Password

If you forgot the password for login, please use serial console and use run level 1 to boot system. Use `passwd` to change the password setting.

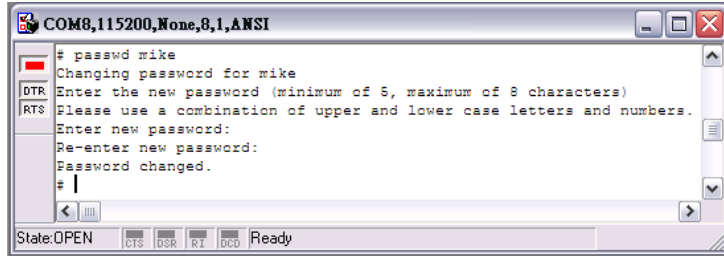

6.2 Forgot the IP Address

If you forgot the PAC-4070 IP address, you can use the Java Manager available on Artilla FTP to search the IP address of PAC-4070.

Or use serial console port to find out the IP address by **`#ifconfig`**.

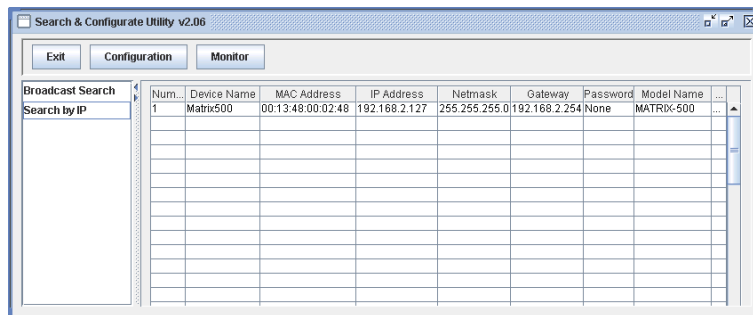

6.3 System Fail to Boot

If you mess up the root file system and make the system fail to boot, PAC-4070 will automatically switch to boot from DataFlash file system and a console menu will show up at console port to help user perform system recovery. **System Recovery Section** will tell you how to recover the system.

7. System Recovery

If NAND Flash file system does fail, DataFlash file system will automatically boot up and a Console Menu at console port will appear as follow:

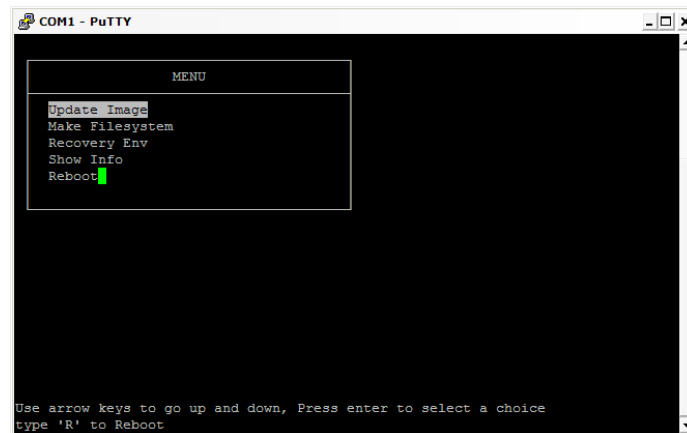

7.1 Update Image

This option can recover the loader, kernel and file system by using an USB disk. The USB disk contains the images files with the path as follow:

Loader: ***pac4000/pac4000.alf***

Kernel: ***pac4000/pac4000K***

File system: ***pac4000/pac4000R***

The files are available on Artila FTP. Please prepare an USB disk and copy the image files to it before choosing this option.

7.2 Make Filesystem

This option is used to create customized file system. Before using this function, you need to copy the folder of ***mkimage504*** on Artila FTP to an USB disk. This function will create a new file system image for users and they can use it to duplicate the customized file system to other PAC-4070.

7.3 Recovery Env.

The option will recover the environment files as default setting. Use this function only when the NAND file system crash.

7.4 Show Info

Show the version information of PAC-4070.

7.5 Reboot

Reboot the NAND flash file system.

7.6 Update Image Starts

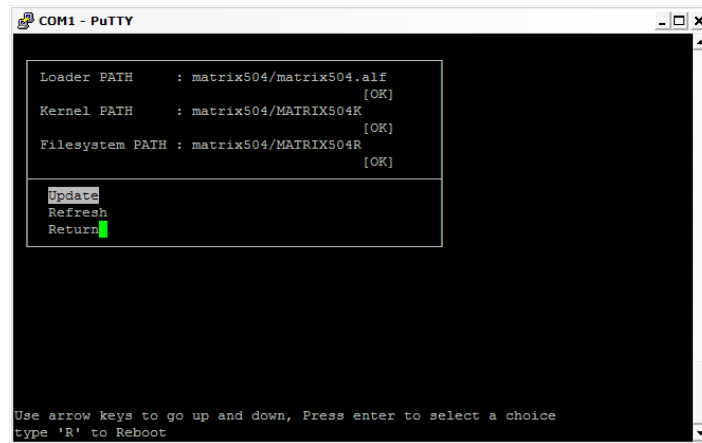

7.7 Update Image Completes

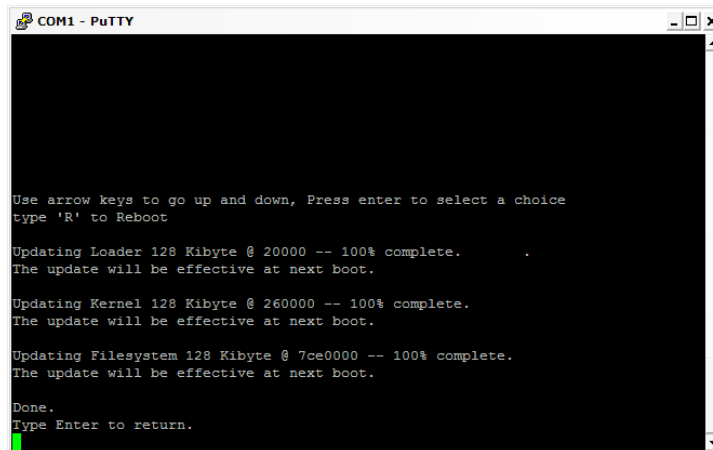

7.8 Make Files System Starts

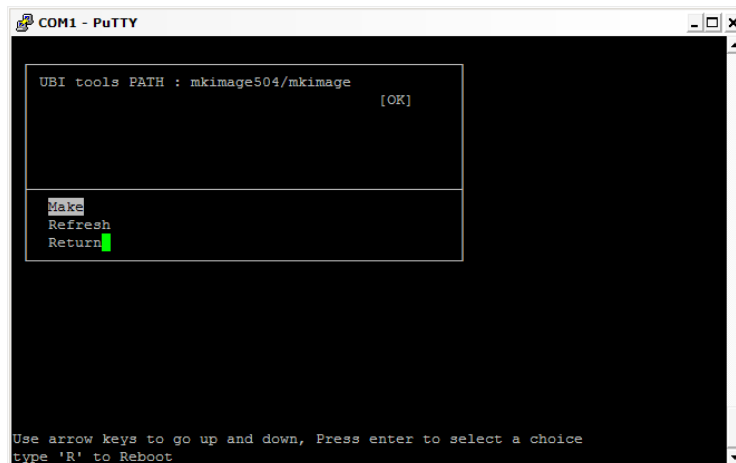

Note

- Use Arrow keys up and down to selection the functions.
- Use Arrow keys left and right to go to higher or lower levels of menu screen.
- To force system go into DataFlash booting, repeatedly keying "!" (Shift +1) right after PAC-4070 power on.

8. Appendix

8.1 Utility Collection

- busybox v1.14.2: tiny utility collection
- sysvinit v2.86: standard Linux initialization
- util-linux-mount/umount v2.12r: support long file name
- ssh v4.6p1: support sftp server
- usbutils v0.7: USB id program
- lighttpd v1.4.28: web server
- wget v1.9.1: used in ipkg software
- iptables v1.3.8: IP routing
- ipkg v.0.99.163: software package management
- procps v3.2.7: support webmin process management
- vsftpd v2.0.5: ftp server
- bash v3.2: GNU shell
- wireless_tools v29: wireless LAN utility
- ppp v2.4.3: ppp dial up utility
- psmics v22.2: procps supplement
- artila utility v.1.1: handy utility added by Artila

You can find more utility on Artila FTP and use ipkg to install the utility.

8.2 ipkg Software Package Management

PAC-4070 uses **ipkg** to manage the software installation, upgrade and removal. Artila will continuously add the kernel module and utility on Artila FTP, user can install these software from Artila FTP. In addition user can also setup your FTP server to update the software you want.

How to setup ipkg via internet

enable DHCP

```
$ udhcpc eth0
```

make sure your network environment can access internet

```
$ ping www.artila.com
```

modify **/etc/ipkg.conf**

add the following two lines

```
src/gz arm http://www.artila.com/download/ipkgs/9G20/utility/
```

```
src/gz kernel http://www.artila.com/download/ipkgs/9G20/modules/
```

comment out other package source

save and quit

execute ipkg update

```
$ ipkg update
```

examples of package installation

```
$ ipkg install pythoncore
```

```
$ ipkg install pythonpyserial
```

How to setup ipkg via USB disk

You can also copy the Utility and module folder from Artila FTP to a USB disk, then use USB disk to install the software by changing the **ipkg.conf**

```
src/gz usb_arm ftp://root:root@127.0.0.1/media/sda1/Utility
```

```
src/gz usb_kernel ftp://root:root@127.0.0.1/media/sda1/modules
```

Make sure the USB disk is correctly mounted, now use command:

```
ipkg update
```

To update the package list and use

```
ipkg install webmin
```

To install webmin. Webmin is a web-based interface to system administration.

To start webmin, go to **/etc/webmin** and type

```
start webmin
```

Then you can use browser to visit PAC-4010 port 10000.

http: //192.168.2.127 : 10000



The webmin for PAC-4070 provides following modules:

- Webmin: webmin configuration
- System: system boot, process and log management
- Server: Apache and SSH server configuration
- Network: network configuration
- Hardware: RTC setting
- Others: File manager, upload and download

Remember to use command:

depmod -a /lib/modules/2.6.29.4/modules.dep

To update the dependency list if new kernel module were added.